

CARDONE ProTech

Supporting Today's Professional Technician



Solving Brake Lockup on Honda/Acura Boosters

Application:

Acura and Honda power brake boosters and master cylinders.

Problem:

Brake lockup occurs after changing power brake booster or master cylinder.

Cause:

Pedal push rod-to-master cylinder piston clearance incorrect. Because of original manufacturer variations, the adjustment between the booster pedal rod and master cylinder must be checked when replacing either unit.

Solution:

Proper adjustment can not be made until vacuum is applied to the booster. To properly adjust the master cylinder push rod, a special gauge is required. Please refer to vehicle service manual for specific procedure and required tool (tool 07JAG-SD40100). See figures 1&2 below.

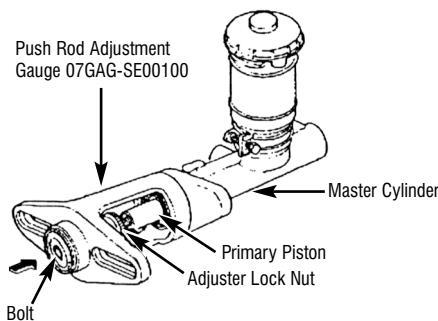

Figure 1: Adjusting Master Cylinder Push Rod

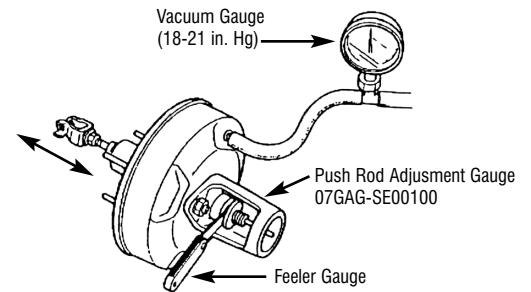

Figure 2: Checking Brake Booster Push Rod Clearance

To adjust rod position, loosen the star lock nut at the base of the booster. Then turn larger hex nut to adjust the push rod-to-piston clearance as needed (see figure 3 below). Tighten star lock nut and install unit as per installation instructions.

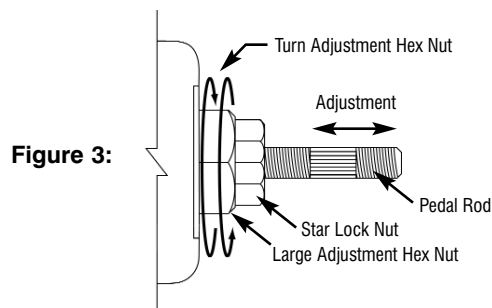

Figure 3:

Turn adjustment nut clockwise to move rod in, counter-clockwise to move rod out.

For other ProTech publications, visit www.cardone.com
CARDONE Industries, Inc. • 5501 Whitaker Ave. • Philadelphia, PA 19124-1799