

CARDONE ProTech

Supporting Today's Professional Technician



GM Opti-Spark Distributor Design Solutions

Application:

All GM engines equipped with OPTI-SPARK Distributors
30-1803, 1832, 1833 (Cap and Rotor supplied)
30-1803H, 1832H, 1833H (Cap, Rotor and Sealed Harness supplied)

Problem:

Premature failure of distributor

Cause:

Inadequate venting, or closed/inoperative distributor Positive Vent System causing condensation to form. The result is internal corrosion, carbon tracking, housing cracks or sensor failure. A leaking water pump allows coolant to seep into the harness causing connector corrosion resulting in poor electrical connection.

Solution:

Installation Tips:

- Verify that units equipped with the Positive Vent System (see design 2 below) do not have lines that are clogged or kinked.
- Check the vacuum source and lines at the intake manifold under the throttle plates for kinks or restrictions.
- Clean debris from housing vents and around distributor housing.
- Use anti-conductive grease when installing connector to prevent corrosion.
- Inspect coolant hoses around distributor for leaks.
- Check connectors for corrosion. Repair or replace vehicle connector as needed.

Unit Identification Guide:

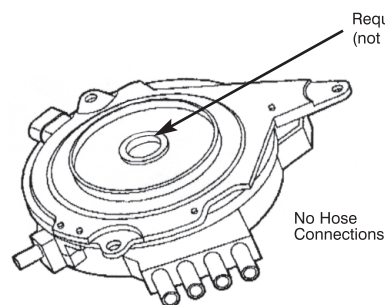

(30-1832)

Design 1

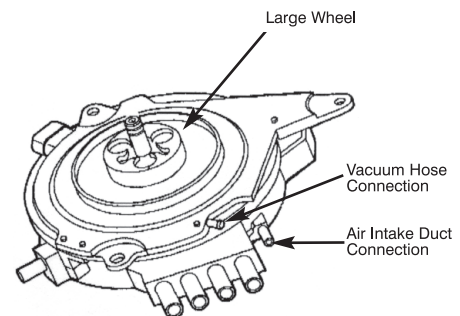

(30-1803 & 1833)

Design 2



SCAN FOR
TECH TIP VIDEO

For other ProTech publications, visit www.cardone.com
CARDONE Industries, Inc. • 5501 Whitaker Ave. • Philadelphia, PA 19124-1799